

MESON'S

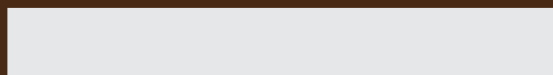

VI ONOLITI

MESON'S

M_ONOLITI



M_onoliti continua il suo percorso di crescita introducendo nuovi linguaggi. Il progetto originario si arricchisce di nuove forme grazie alla possibilità di accostare basi M_onoliti e M_onoliti gola, consentendo di prevedere la gola nella posizione più opportuna. La gamma delle finiture aumenta di numero con l'introduzione di nuovi laminati caratterizzati da una forte matericità; contemporaneamente, l'opportunità di utilizzare due diverse finiture sulla stessa base, crea piacevoli sovrapposizioni di volumi e finiture.

M_onoliti continues its growth process by introducing new languages. The original project has been enhanced with new forms thanks to the possibility to approach M_onoliti base units and M_onoliti base units with grip recess, allowing to provide the grip recess in the most appropriate position. The range of finishes increases with the introduction of new laminates characterized by a strong materiality; at the same time, the opportunity to use two different finishes on the same base unit, creates pleasant overlapping of volumes and finishes.

M_ONOLITI

INDEX

C01	6
C02	24
C03	38
C04	52
C05	64
C06	80
C07	92
C08	108
C09	122

LAMINATO MALTA GRIGIA
MATERICO SETA PIOMBO

Volumi che si sovrappongono e si fondono in un unico blocco attrezzato: nasce un nuovo concetto di isola in cucina. L'integrazione di forme pure è lo strumento progettuale che soddisfa contemporaneamente l'esigenza di rigore estetico e il bisogno di funzionalità.

Volumes that overlap and merge into a single equipped block: a new concept of island is born in the kitchen. The integration of pure forms is the project tool that simultaneously satisfies the need of aesthetic rigor and the need for functionality.







La combinazione di laminato Malta Grigia e materico seta Piombo conferisce eleganza e raffinatezza a questa composizione M_onoliti.

The combination of Malta Grigia laminate and Seta Piombo textured-melamine gives elegance and sophistication to this M_onoliti composition.





Zona lavaggio e cottura sono perfettamente integrate e nascoste da piani a ribalta in acciaio. Con un semplice movimento di apertura si accede alla zona operativa e in un attimo si richiude tutto, riportando l'ordine in cucina.

Washing and cooking area are perfectly integrated and hidden by steel covers. With a simple opening movement you can access to the operational area and in a moment you can close everything, restoring order in the kitchen.





Le colonne sporgenti che ospitano i forni, evidenziano il confine tra un blocco e l'altro, dando ritmo e profondità alla composizione. Lo spazio viene sfruttato al meglio grazie agli elementi sopra-colonna.

The overhanging tall units with ovens show the border between one block and the other, giving rhythm and depth to the composition. The space is fully exploited, thanks to the tall unit top elements.



LAMINATO METALLO TADAO
LACCATO GRIGIO CORDA OPACO

Grazie all'accosto di basi M_onoliti e M_onoliti gola, il laminato Metallo Tadao del blocco cassetti, si assottiglia diventando piano di lavoro, sopra le ante in laccato opaco Grigio Corda.

Thanks to the approach of M_onoliti base units and M_onoliti base units with grip recess, the Metallo Tadao laminate of the drawer block thins, becoming worktop, above the doors are in Grigio Corda matt lacquer.







I frontali in laccato opaco Grigio Corda fanno da sfondo al laminato Metallo Tadao che disegna i volumi della cucina e la completa con una boiserie nella stessa finitura.

The fronts in Grigio Corda matt lacquer form the background to the Metallo Tadao laminate that draws the volumes of the kitchen and completes it with a wood paneling in the same finish.



Il nuovo modulo del Sistema Contengo contribuisce allo sviluppo orizzontale del progetto, permettendo allo stesso tempo di disporre agevolmente di tutto il necessario. Anche questo nuovo modulo può ospitare pratici cassetti.

The new module of Contengo System contributes to the horizontal development of the project, allowing at the same time to have easily everything you need. Even this new module can accommodate practical drawers.







Una cucina senza compromessi nella quale un'isola dal carattere forte, esalta il piano a sbalzo in laminato Pietra Emperador, protagonista assoluto della composizione. Il tono delicato e rassicurante del materico seta Seppia garantisce il necessario equilibrio.

A kitchen without compromises, in which an island with a strong character enhances the overhanging worktop in Pietra Emperador laminate, the absolute protagonist of the composition. The gentle and reassuring tone of the Seta Seppia textured-melamine guarantees the necessary balance.







Il piano cottura ad induzione è accolto nel generoso spessore del piano di lavoro a sbalzo, sorretto da una lastra in vetro che crea un piacevole effetto sospensione.

The induction hob is housed in the generous thickness of the overhanging worktop, supported by a glass pane which creates a pleasant effect of suspension.



Un semplice movimento svela il prezioso contenuto dell'elemento a sbalzo, con apertura verticale. Si possono prevedere semplici ripiani ma anche celare forni compatti, microonde, forno-vapore, macchina del caffè ecc.

A simple movement reveals the precious content of the overhanging element, with vertical opening. It may contain simple shelves but also hide compact ovens, microwave, steam oven, coffee machine etc.







In questa composizione, gli elementi destinati alla preparazione, al lavaggio ed alla cottura del cibo, sono evidenziati dal laminato Pietra Botticino. L'elemento sporgente, emerge dalle colonne più chiare, mentre le finiture delle basi si alternano in piacevoli contrasti materici.

In this composition, the elements for the preparation, washing and cooking of food are highlighted by the Pietra Botticino laminate. The overhanging element emerges from the lighter tall units, while the finishes of the base units are alternated in pleasant contrasting materials.







L'esile profilo del piano di lavoro, grazie alla continuità della finitura, diventa un capiente cestone estraibile. Mutano i volumi, si alternano materiali e finiture, dando vita a nuove e sorprendenti geometrie.

The thin profile of the worktop, thanks to the continuity of the finish, becomes a capacious removable deep drawer. The volumes change, the materials and finishes are alternated, creating new and surprising geometries.



Nuove ed affidabili tecnologie consentono il rivestimento del lavello in acciaio, con lo stesso laminato del piano di lavoro, saldandone e sigillandone i bordi. Il lavello è caratterizzato da uno scarico perimetrale. La piletta centrale nascosta dal fondo in laminato rimane accessibile mediante l'agevole rimozione dello stesso.

New and reliable technologies enable the coating of the steel sink with the same laminate of the worktop, by welding and sealing the edges. The sink is characterized by a perimeter drain. The central drain, hidden by the laminate bottom, remains accessible through its easy removal.





In questa cucina, colonne, sopracolonne e pensili, accomunati della stessa finitura, garantiscono un generoso volume destinato al contenimento. Sulle basi con penisola in laminato Pietra Calacatta, sovrastate dal piano di lavoro dello stesso materiale, avviene il quotidiano rito della preparazione dei pasti.

In this kitchen tall units, tall unit top elements and wall units, which share the same finish, guarantee a generous volume designed to contain. On the base units with peninsular unit in Pietra Calacatta laminate and worktop in the same material, the daily ritual of preparing meals takes place.







Questa composizione è concepita come un blocco mono-materico; lo stesso materiale nella medesima finitura, è applicato a tutti i componenti della cucina. Frontali, gola, zoccolo e piano di lavoro si allineano facilitando pulizia e manutenzione delle superfici.

This composition is designed as a mono-material block; the same material in the same finish is applied to all components of the kitchen. Fronts, grip recess, plinth and worktop are aligned, facilitating the cleaning and maintenance of surfaces.

Il lavello rivestito dello stesso materiale del piano di lavoro, ne diventa parte integrante. La pulizia e la manutenzione dello stesso, è facilitata dalla continuità della finitura e dall'assenza di fughe tra una superficie e l'altra.

The sink covered with the same material of the worktop becomes an integral part. The cleaning and maintenance of the same is facilitated by the continuity of the finish and the absence of joints between one surface and the other.







La cappa Maestrale a parete, con copri-filtro e cielo color rame, caratterizza la parete, diventando un vero e proprio elemento d'arredo. La finitura rame, pur emergendo dal contesto della composizione, si integra perfettamente, creando quel giusto equilibrio tra colore dei materiali e purezza delle forme.

The Maestrale wall hood, with filter cover and top panel in copper colour, characterizes the wall, becoming a real piece of furniture. The copper finish, emerging from the context of the composition, is perfectly integrated, creating the right balance between colour of materials and purity of forms.





L'accostamento di volumi e materiali crea un contesto domestico armonioso, contrassegnato dalla presenza di elementi a giorno, nei quali alloggiare ciò che si desidera avere sempre a portata di mano.

The combination of volumes and materials creates a harmonious domestic context, marked by the presence of open elements, in which to put what you want to always have to hand.







Nell'elegante elemento sotto-pensile a giorno, trovano spazio le ciotole preferite ma anche le spezie e i sapori più utilizzati.

In the elegant element under wall unit, there are the favourite bowls but also the most used spices and flavours.





LAMINATO MALTA BIANCA
LAMINATO MALTA CANAPA

Su un blocco in laminato Malta Canapa, destinato alla cottura e alla convivialità, sventa una boiserie sviluppata in verticale, nella medesima finitura. Il resto della cucina in laminato Malta Bianca si integra perfettamente con le pareti circostanti.

On a block in Malta Canapa laminate, made for cooking and conviviality, stands a vertical wall panelling in the same finish. The rest of the kitchen in Malta Bianca laminate integrates perfectly with the surrounding walls.







Una progettazione efficiente si ispira a precisi canoni di ergonomia e funzionalità. L'organizzazione dello spazio destinato al contenimento è affidata a grandi cestoni estraibili e ad elementi angolari, che consentono lo sfruttamento completo dello spazio.

An efficient planning is inspired by precise canons of ergonomics and functionality. The organization of the space for containment is provided by capacious removable deep drawers and corner elements, which allow the full exploitation of space.



La boiserie è un progetto di rivestimento della parete mediante pannelli e mensole, le cui finiture si possono scegliere, tra quelle usate per la cucina. Il piano snack è l'appoggio ideale per una colazione o un aperitivo; ma anche una comoda superficie su cui posare le pietanze preparate, prima di portarle in tavola.

The wall panelling is a wall cladding project by means of panels and shelves, whose finishes can be selected from those used for the kitchen. The breakfast bar is the ideal starting point for a breakfast or an aperitif; but also a comfortable surface on which to lay the prepared dishes, before bringing them on the table.







LAMINATO METALLO LAMIERA
MATERICO CEMENTO

La combinazione di diversi materiali è uno strumento progettuale, da usare con sapienza ed equilibrio. In questa composizione è rappresentata al meglio, la capacità di associare due finiture, sovrapponendo due blocchi distinti nella stessa base.

The combination of different materials is a design tool, to use with wisdom and balance. This composition represents the best ability to associate two finishes, overlaying two separate blocks in the same base unit.







La continuità orizzontale, creata dai frontali cassetto in laminato Metallo Lamiera, è interrotta dalla "torre" verticale, ottenuta applicando al pensile la stessa finitura.

The horizontal continuity, created by the drawer fronts in Metallo Lamiera laminate, is interrupted by the vertical "tower", obtained by applying the same finish to the wall unit.







LAMINATO PIETRA CALACATTA
MATERICO SETA DIAMANTE

Le opportunità progettuali di M_onoliti sono ben rappresentate da questa composizione; materiali, altezze e profondità diverse, danno vita ad una alternanza unica di volumi e finiture.

The design opportunities of M_onoliti are well represented by this composition; materials, heights and depths create a unique alternation of volumes and finishes.







Il laminato Pietra Calacatta impreziosisce il piano di lavoro e lo schienale, rivestendo inoltre cassetti e cestoni estraibili superiori.

The Pietra Calacatta laminate embellishes the worktop and back panel, coating also upper drawers and removable deep drawers.



Il pensile composto è formato da una doppia scocca con unica anta, caratterizzata da una ergonomica apertura verticale. Al suo interno trova posto la cappa e un vano contenitore. Questa cucina è inoltre dotata di una pratica barra in acciaio inox porta-accessori.

The composed wall unit is formed by a double carcass with a single door, characterized by an ergonomic vertical opening. Inside, there is the hood and a storage compartment. This kitchen is also equipped with a practical stainless steel utensil hanging rail.







FINISHES

MATERICI SETA / SETA TEXTURED-MELAMINE

MATERICI / TEXTURED-MELAMINE

LAMINATI / LAMINATE

FENIX / FENIX

LACCATI OPACHI E LUCIDI
MATT AND GLOSS LACQUERS

LACCATI OPACHI SETA
SETA MATT LACQUER

MATERICI SETA
SETA TEXTURED-MELAMINE

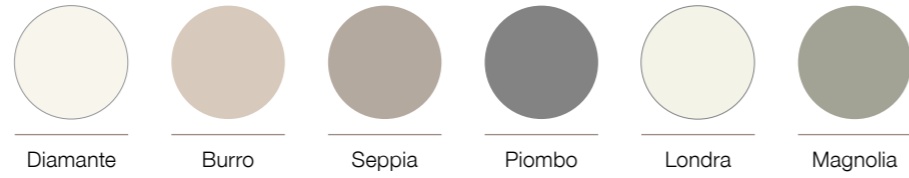

MATERICI
TEXTURED-MELAMINE

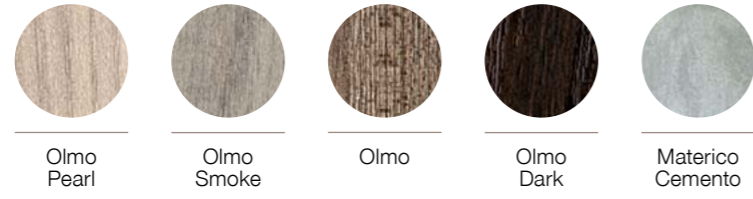

LAMINATI
LAMINATE

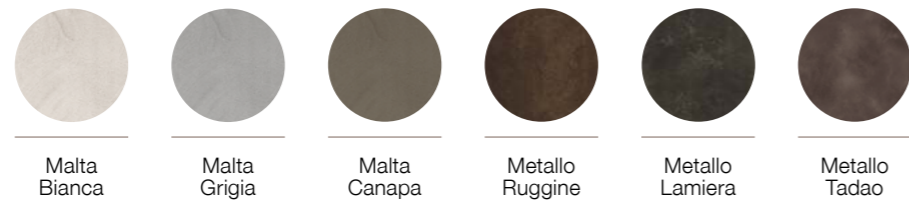

FENIX
FENIX

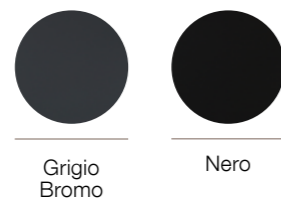
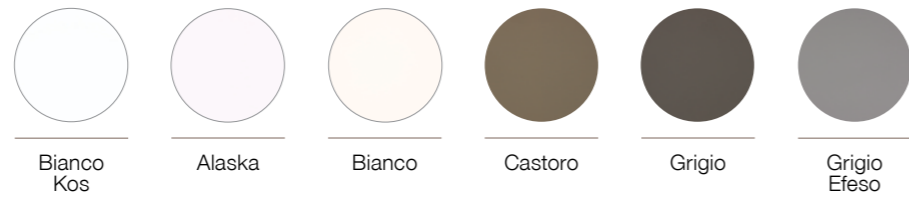

LACCATI
OPACHI E LUCIDI
MATT AND GLOSS
LACQUERS

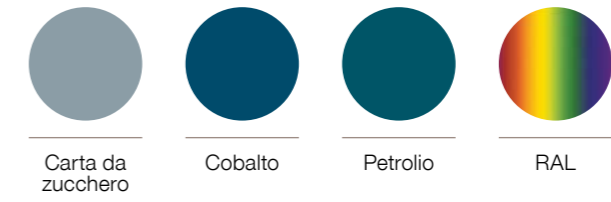
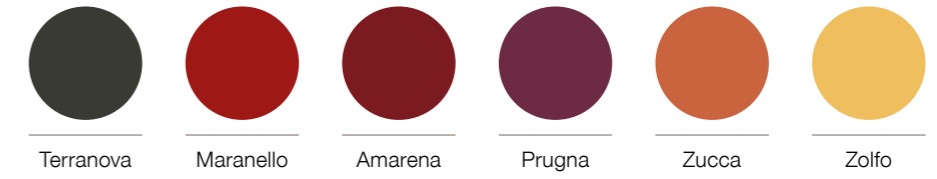
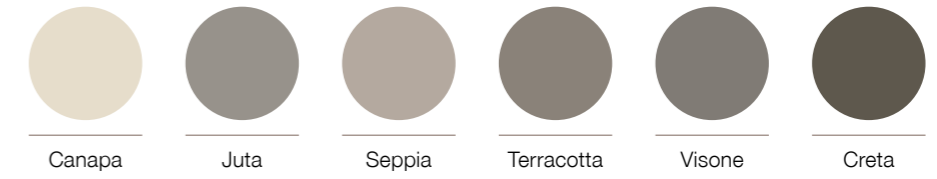
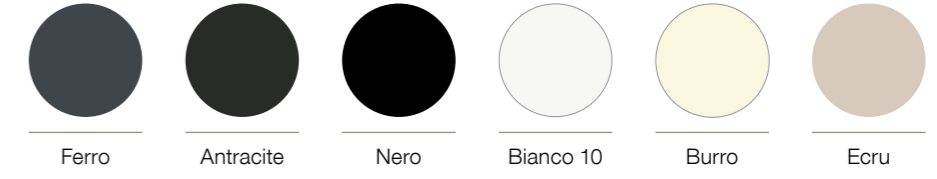
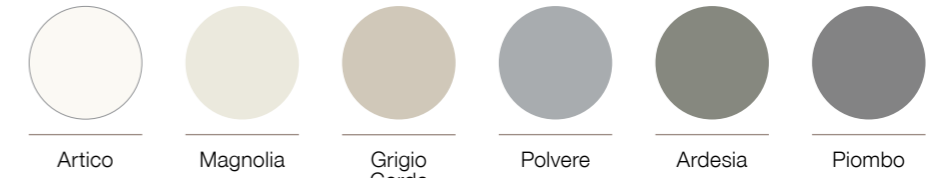

LACCATI
OPACHI SETA
SETA MATT
LACQUER

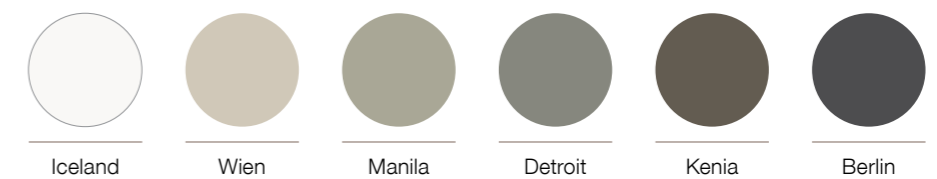

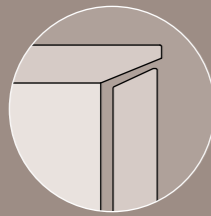

- laminato Malta Grigia
Malta Grigia laminate
- materico seta Piombo
Seta Piombo textured-melamine

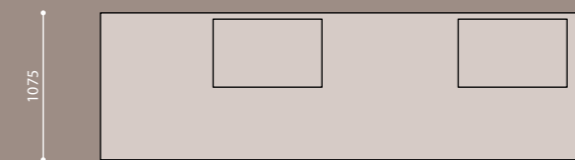
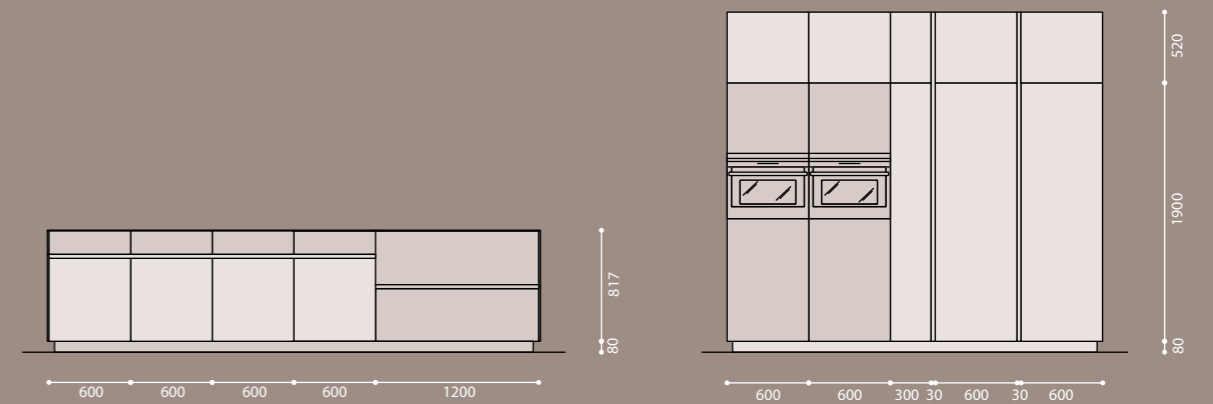
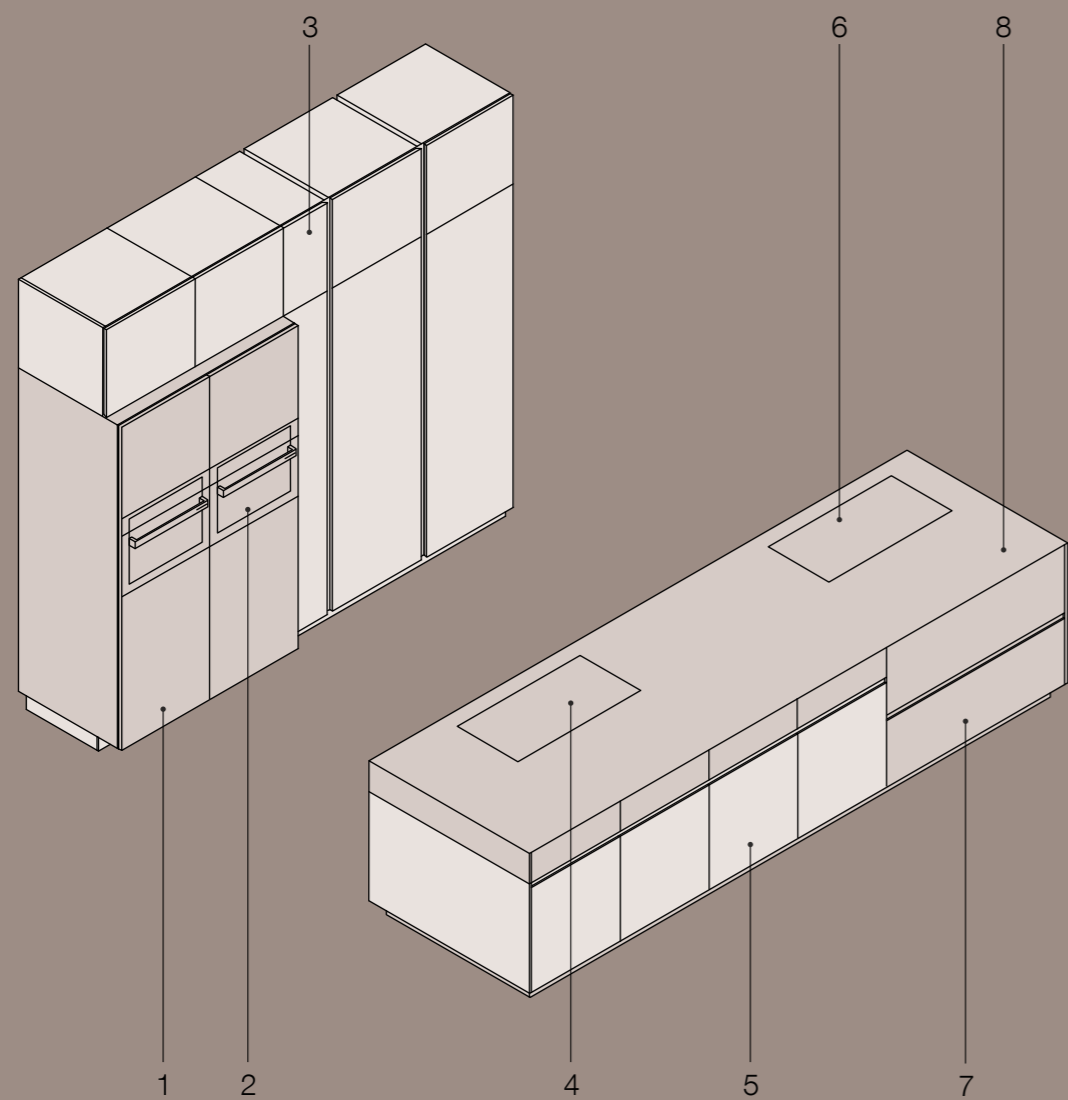

- 01. Colonne sporgenti h 1900, frontale materico seta Piombo
- 02. Forni, Barazza
- 03. Colonne h 1900 con sopracolonna 520, frontale laminato Malta Grigia
- 04. Piano cottura a scomparsa, Barazza

- 05. M_onoliti, frontale cassetto materico seta Piombo, frontale anta laminato Malta Grigia
- 06. Lavello a scomparsa, Barazza
- 07. M_onoliti, frontale materico seta Piombo
- 08. Piano di lavoro materico seta Piombo

- 01. Overhanging tall units h 1900, Seta Piombo textured-melamine front
- 02. Ovens, Barazza
- 03. Tall units h 1900 with tall unit top element h 520, Malta Grigia laminate front
- 04. Concealed hob, Barazza

- 05. M_onoliti, Seta Piombo textured-melamine drawer front, Malta Grigia laminate door front
- 06. Concealed sink, Barazza
- 07. M_onoliti, Seta Piombo textured-melamine front
- 08. Seta Piombo textured-melamine worktop

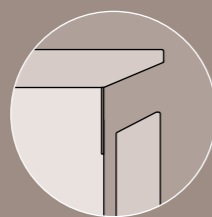
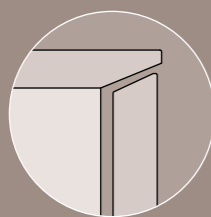

- laccato opaco Grigio Corda
Grigio Corda matt lacquer
- laminato Metallo Tadao
Metallo Tadao laminate

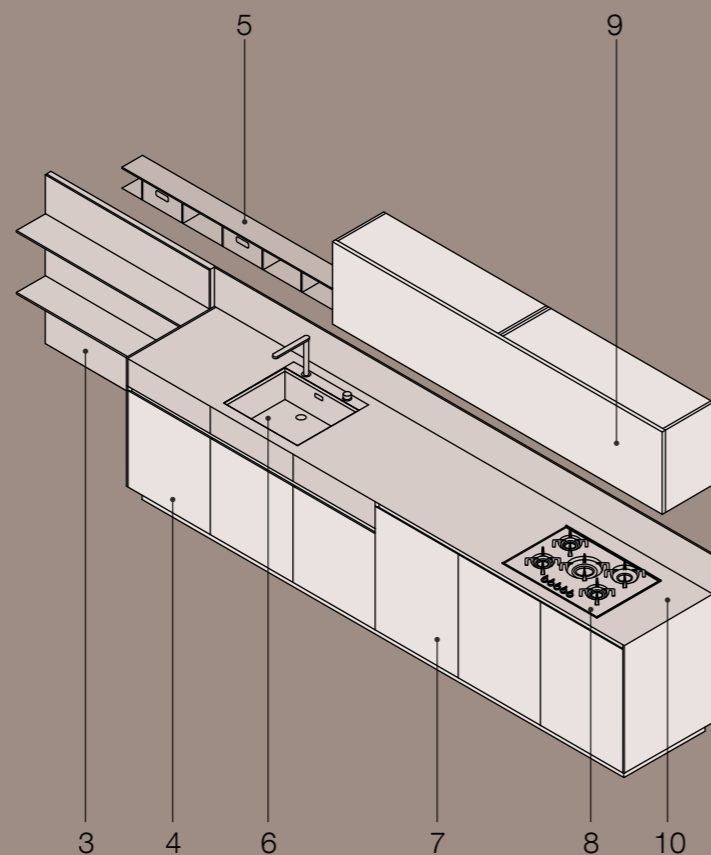
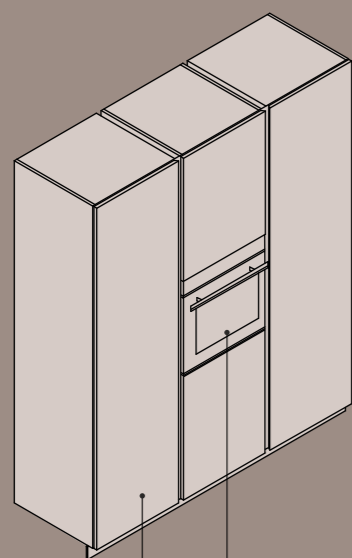

1

2

3

4

6

7

8

10

5

9

M_onoliti: M
M_onoliti gola: MG

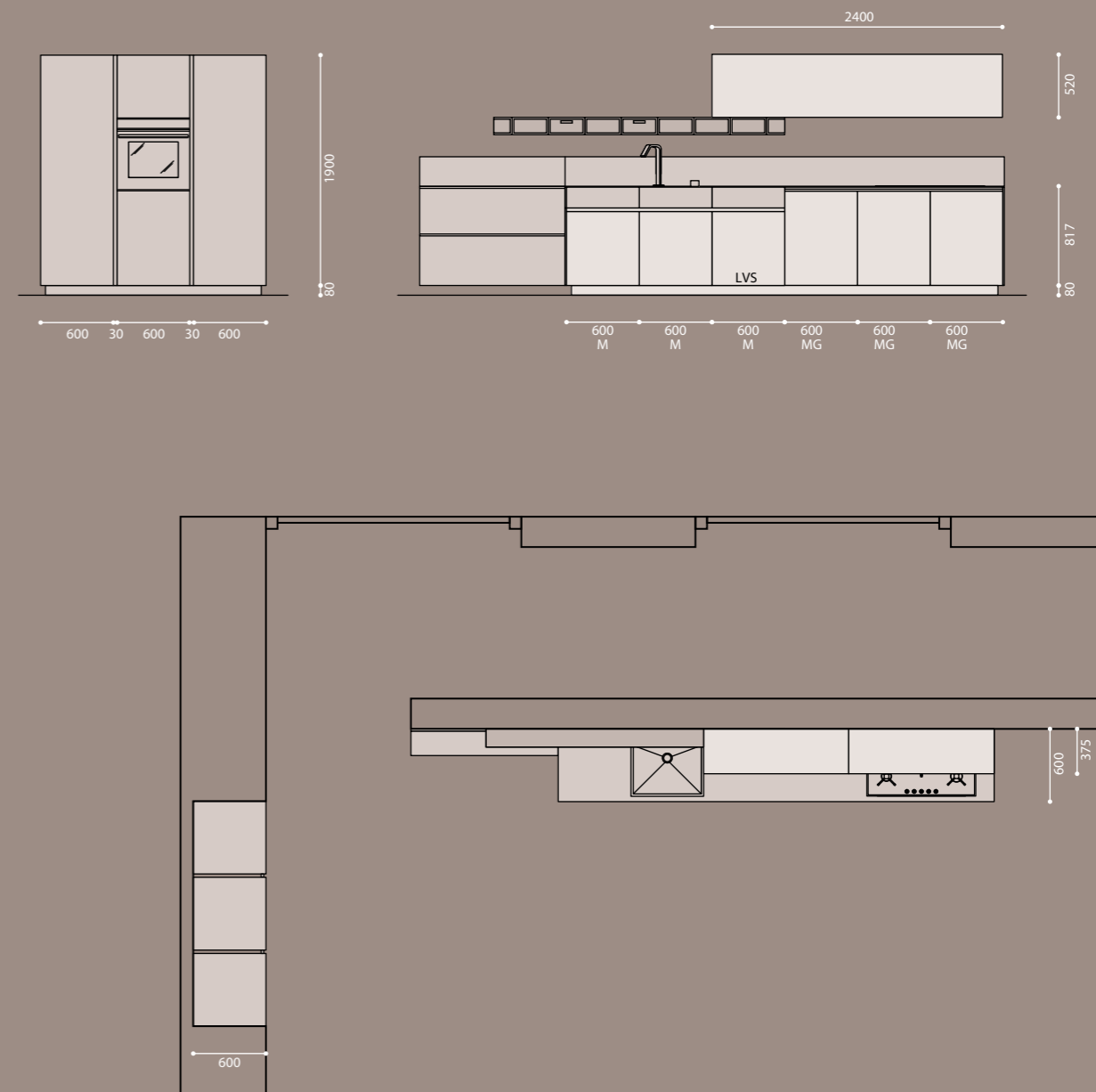

01. Colonne h 1900, frontale laminato Metallo Tadao
02. Forno con profili in rame, Smeg
03. Boiserie, pannello e mensole laminato Metallo Tadao
04. Base M_onoliti, frontale cassetto laminato Metallo Tadao e frontale anta laccato opaco Grigio Corda
05. Elemento contengo
06. Lavello acciaio sottotop, Foster

07. Base M_onoliti gola, frontale laccato opaco Grigio Corda
08. Piano cottura con profili in rame, Smeg
09. Pensile composto (1200 + 1200), anta unica, frontale laccato opaco Grigio Corda con apertura vasistas e cappa incassata
10. Piano di lavoro laminato Metallo Tadao

01. Tall units h 1900, Metallo Tadao laminate front
02. Oven with copper profiles, Smeg
03. Wall panelling, panel and shelves in Metallo Tadao laminate
04. M_onoliti base unit, Metallo Tadao laminate drawer front and Grigio Corda matt lacquer door front
05. Contengo element
06. Undermounted steel sink, Foster

07. M_onoliti base unit with grip recess, Grigio Corda matt lacquer front
08. Hob with copper profiles, Smeg
09. Composed wall unit (1200 + 1200), entire door, Grigio Corda matt lacquer front with top-hung door and built-in hood
10. Metallo Tadao laminate worktop

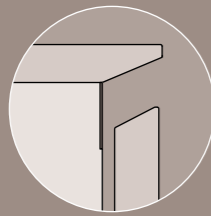

- materico seta Seppia
Seta Seppia textured-melamine
- laminato Pietra Emperador
Pietra Emperador laminate

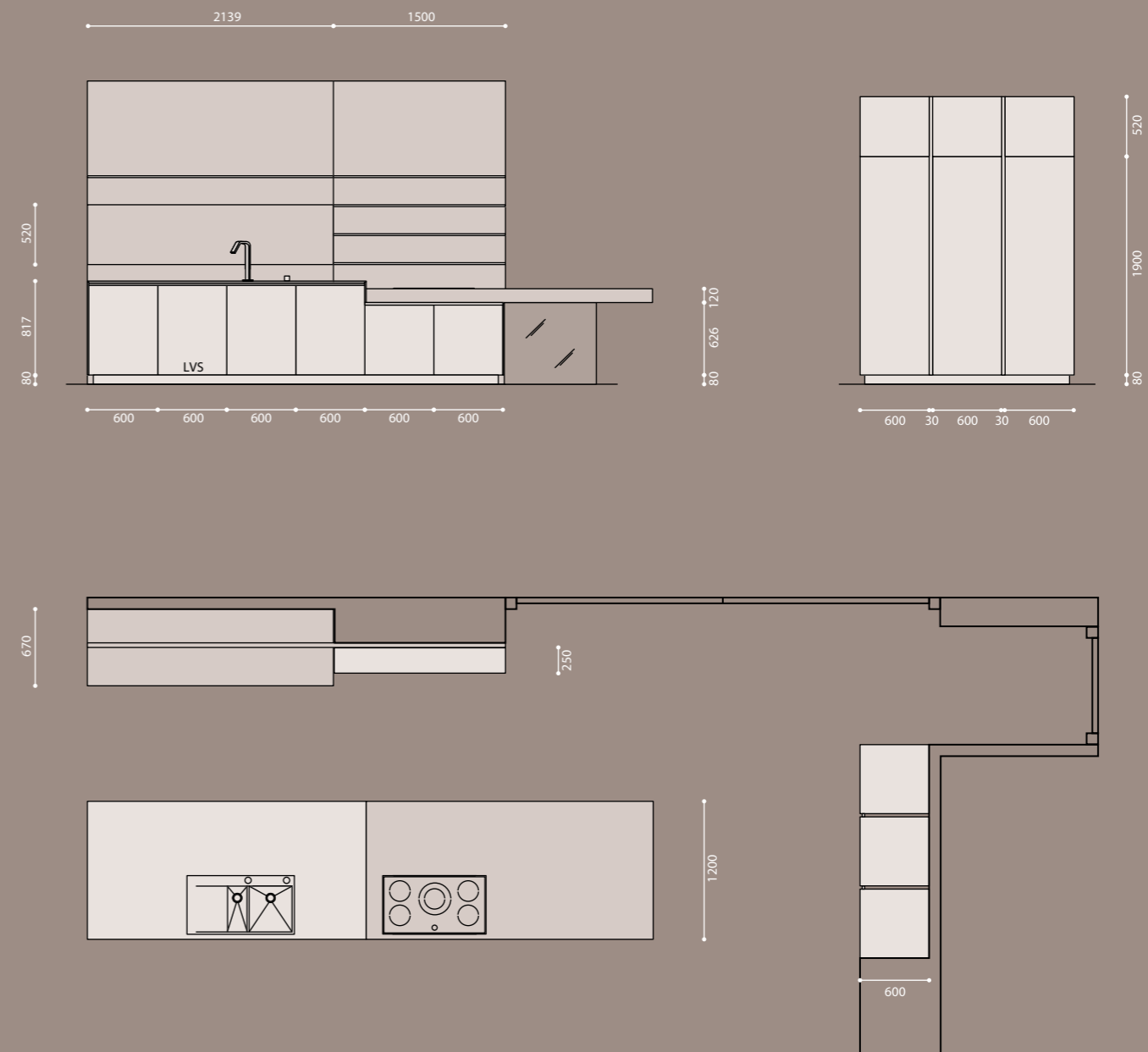
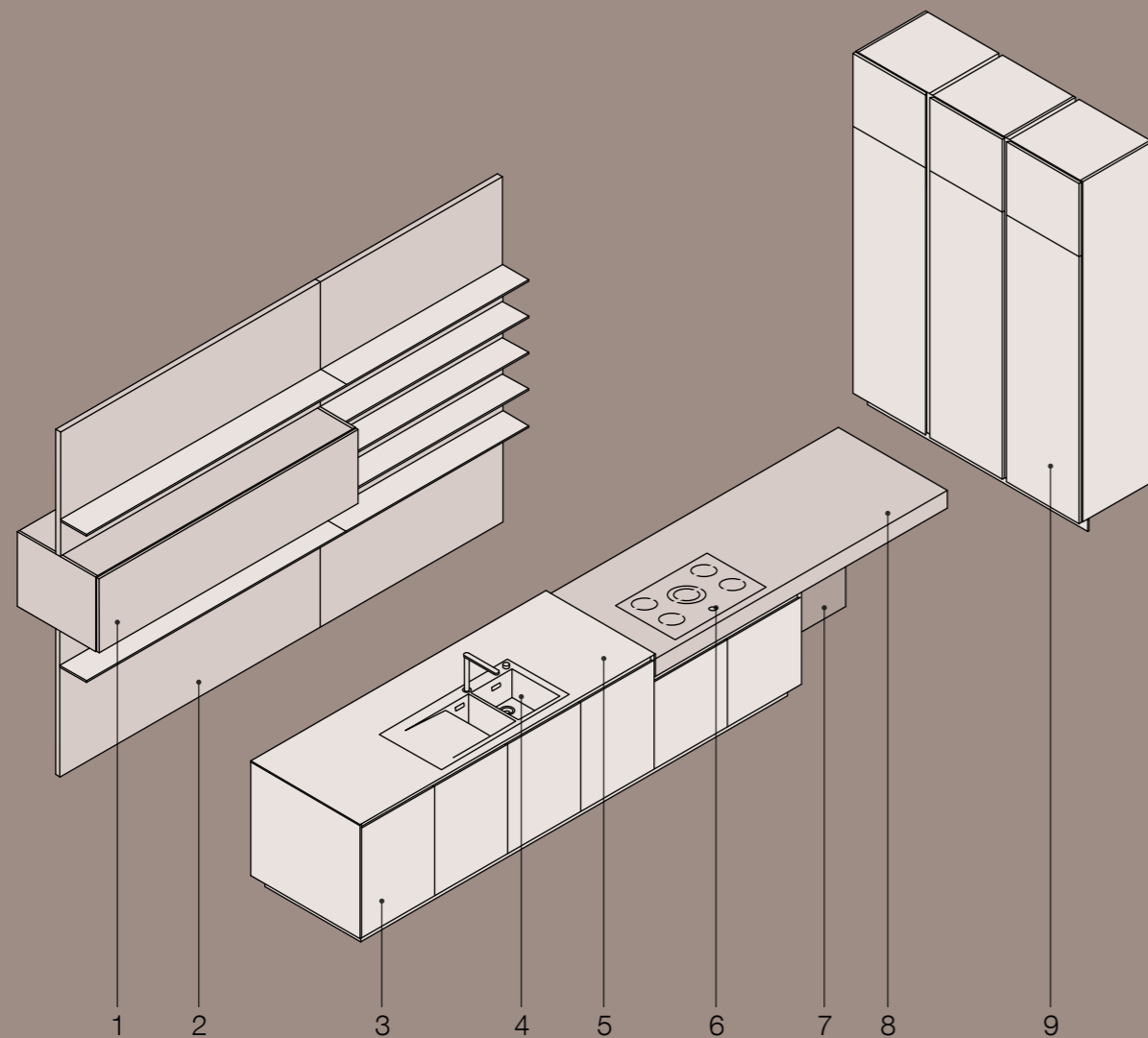

- 01. Elemento sporgente, frontale laminato Pietra Emperador con apertura planare verticale e forno ad incasso, Miele
- 02. Boiserie, pannelli laminato Pietra Emperador, mensole materico seta Seppia
- 03. Base M_onoliti gola, frontale materico seta Seppia
- 04. Lavello acciaio, Blanco
- 05. Piano di lavoro materico seta Seppia
- 06. Piano cottura ad induzione, Miele
- 07. Gambone vetro
- 08. Piano, laminato Pietra Emperador
- 09. Colonne h 1900 con sopracolonne h 520, frontale materico seta Seppia

- 01. Overhanging element, Pietra Emperador laminate front with lift-up opening and built-in oven, Miele
- 02. Wall panelling, panels in Pietra Emperador laminate, shelves in Seta Seppia textured-melamine
- 03. M_onoliti base unit with grip recess, Seta Seppia textured-melamine front
- 04. Steel sink, Blanco
- 05. Seta Seppia textured-melamine worktop
- 06. Induction hob, Miele
- 07. Glass Leg
- 08. Worktop, Pietra Emperador laminate
- 09. Tall units h 1900 with tall unit top elements h 520, Seta Seppia textured-melamine front

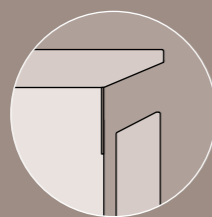
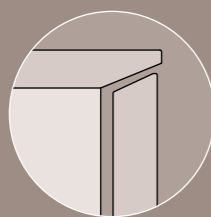

- materico seta Diamante
Seta Diamante textured-melamine
- laminato Pietra Botticino
Pietra Botticino laminate

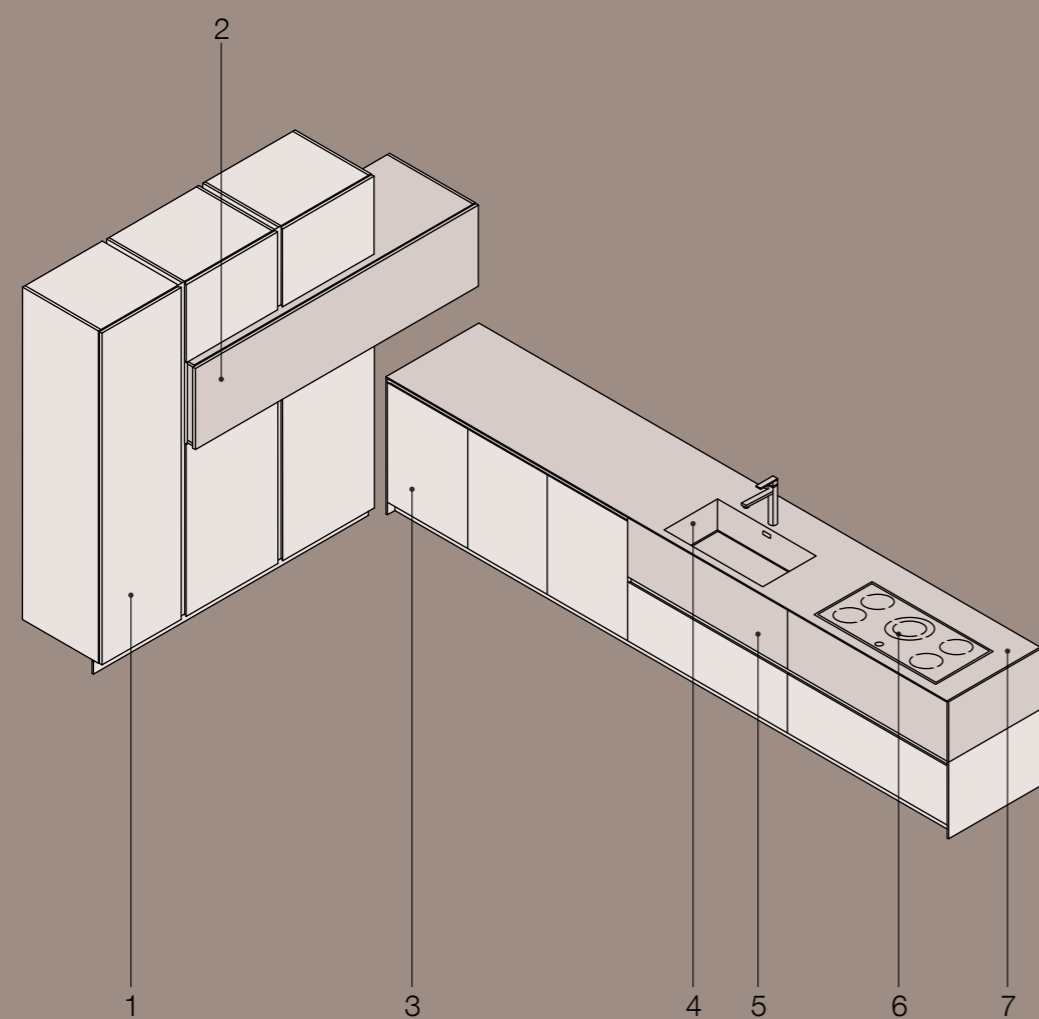

M_onoliti: M
M_onoliti gola: MG

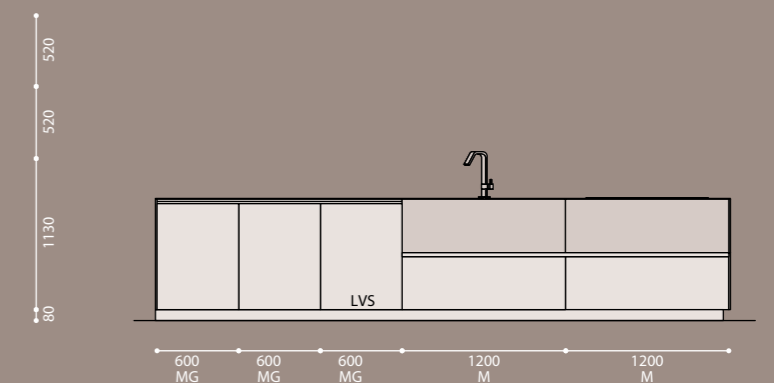
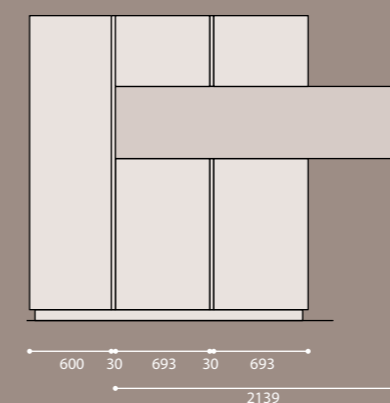

- 01. Colonne h 2160, frontale materico seta Diamante
- 02. Elemento sporgente, frontale laminato Pietra Botticino, con apertura planare verticale e forno ad incasso, Siemens
- 03. Base M_onoliti gola, frontale anta materico seta Diamante
- 04. Lavello integrato unicolor, 740 x 400
- 05. Base M_onoliti, frontale primo cestone laminato pietra Botticino, secondo cestone materico seta Diamante
- 06. Piano cottura ad induzione, Siemens
- 07. Piano di lavoro unicolor Pietra Botticino

- 01. Tall units h 2160, Seta Diamante textured-melamine front
- 02. Overhanging element, Pietra Botticino laminate front, with lift-up opening and built-in oven, Siemens
- 03. M_onoliti base unit with grip recess, Seta Diamante textured-melamine door front

- 04. Unicolor integrated sink, 740 x 400
- 05. M_onoliti base unit, front of first deep drawer in Pietra Botticino laminate, second deep drawer in Seta Diamante textured-melamine
- 06. Induction hob, Siemens
- 07. Unicolor Pietra Botticino worktop

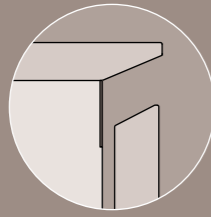

- laminato Pietra Calacatta
Pietra Calacatta laminate
- materico seta Piombo
Seta Piombo textured-melamine

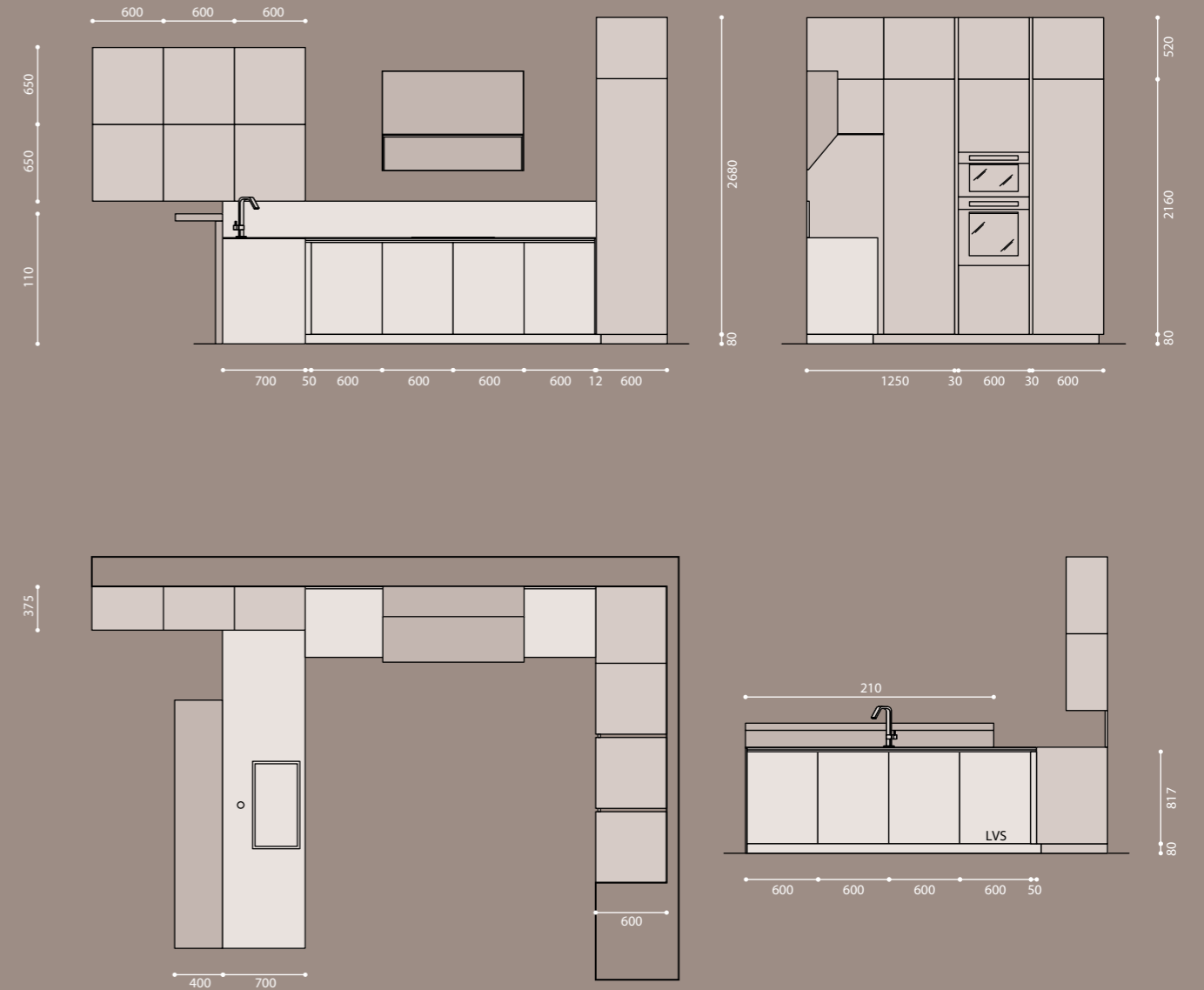
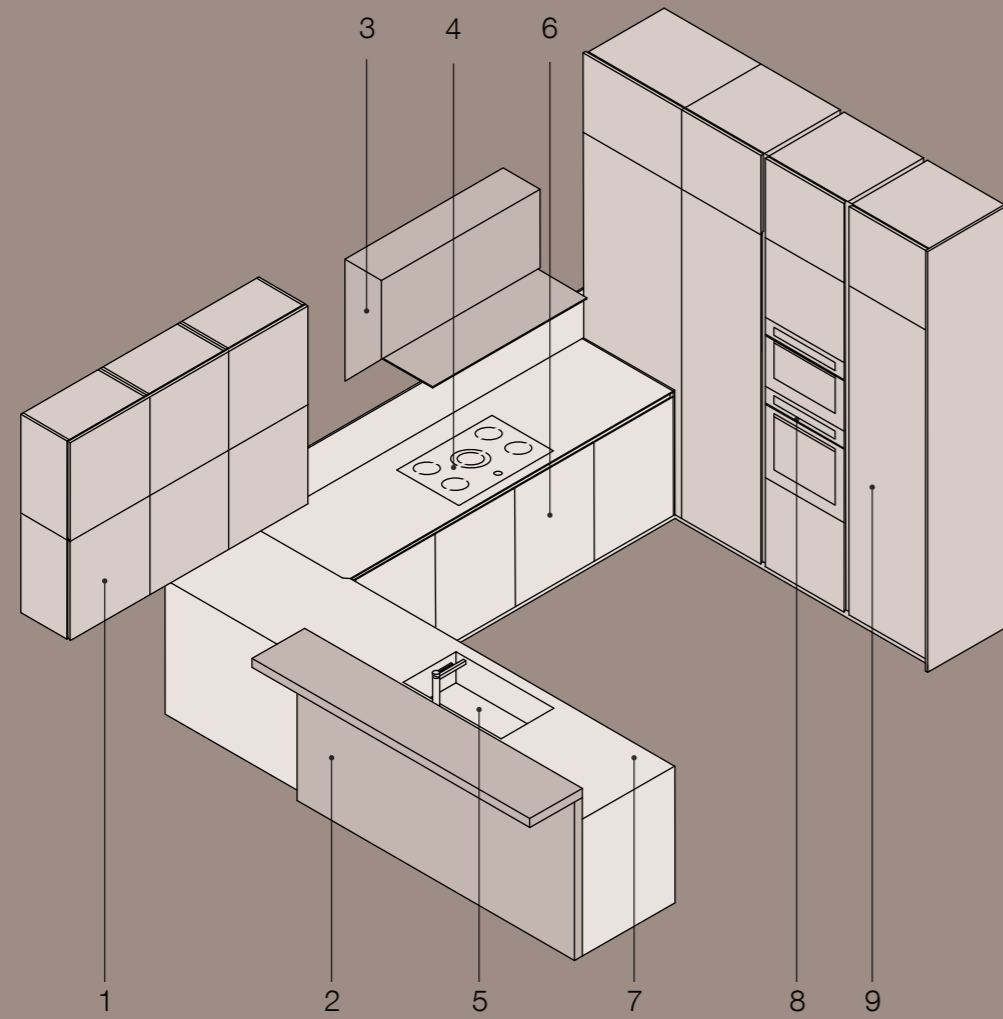

- 01. Pensili, frontale materico seta Piombo
- 02. Piano snack, Rovere Nodato Naturale
- 03. Cappa parete Maestrone, Meson's
- 04. Piano cottura ad induzione, Whirlpool
- 05. Lavello integrato unicolor, 740 x 400

- 06. Base M_onoliti gola, frontale laminato Pietra Calacatta
- 07. Piano di lavoro unicolor Pietra Calacatta
- 08. Forno e microonde, Whirlpool
- 09. Colonne h 2160 con sopra colonne h 520, frontali materico seta Piombo

- 01. Wall units, Seta Piombo textured-melamine front
- 02. Breakfast bar, Natural Knotted Oak
- 03. Maestrone wall hood, Meson's
- 04. Induction hob, Whirlpool
- 05. Unicolor integrated sink, 740 x 400

- 06. M_onoliti base unit with grip recess, Pietra Calacatta laminate front
- 07. Unicolor Pietra Calacatta worktop
- 08. Oven and microwave, Whirlpool
- 09. Tall units h 2160 with tall unit top elements h 520, Seta Piombo textured-melamine fronts

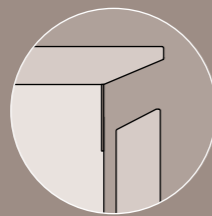
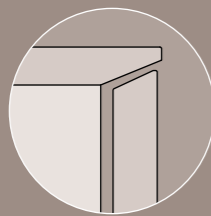

-  fenix Grigio Efeso
-  fenix Grigio Efeso
-  fenix Grigio Bromo
-  fenix Grigio Bromo

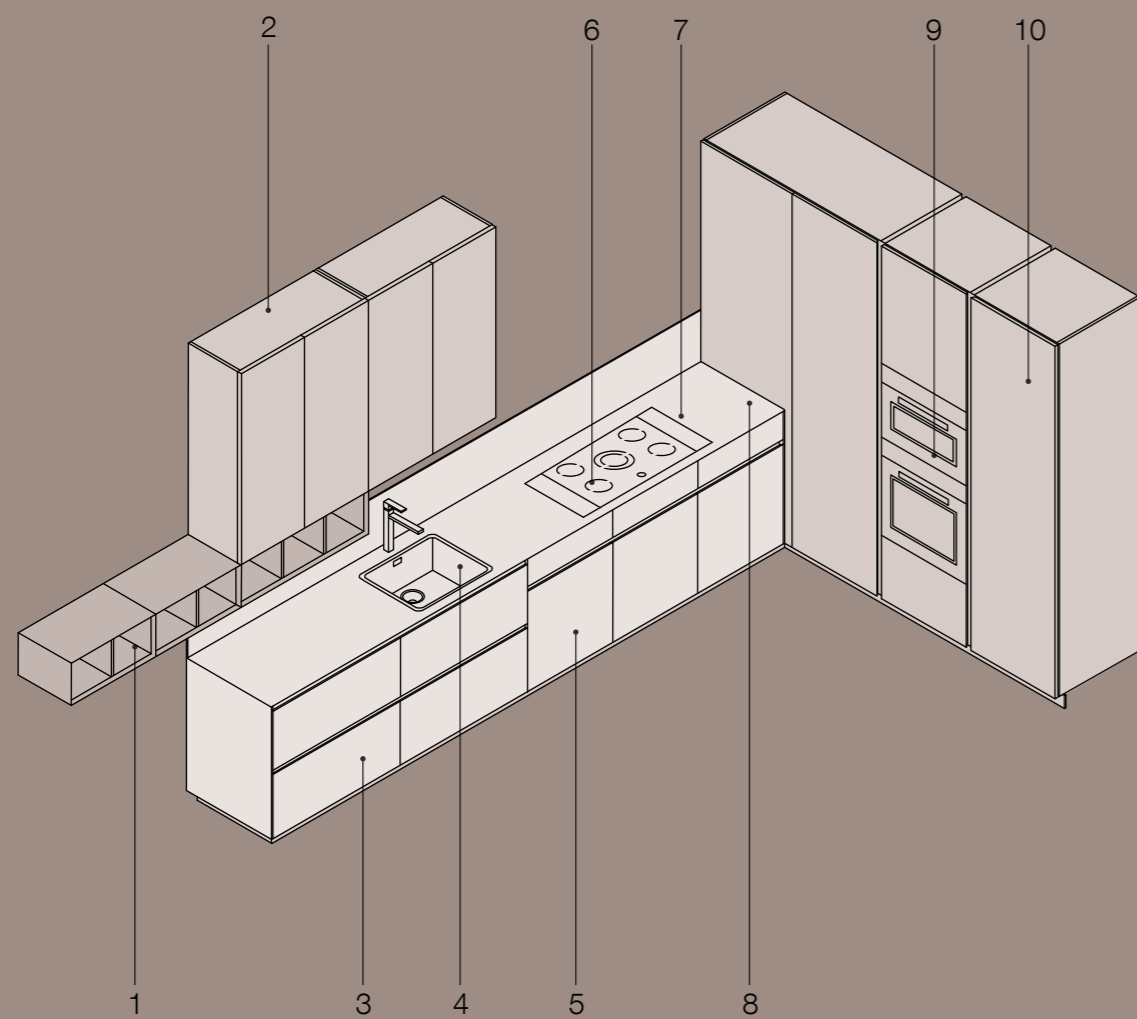

M_onoliti: M
M_onoliti gola: MG

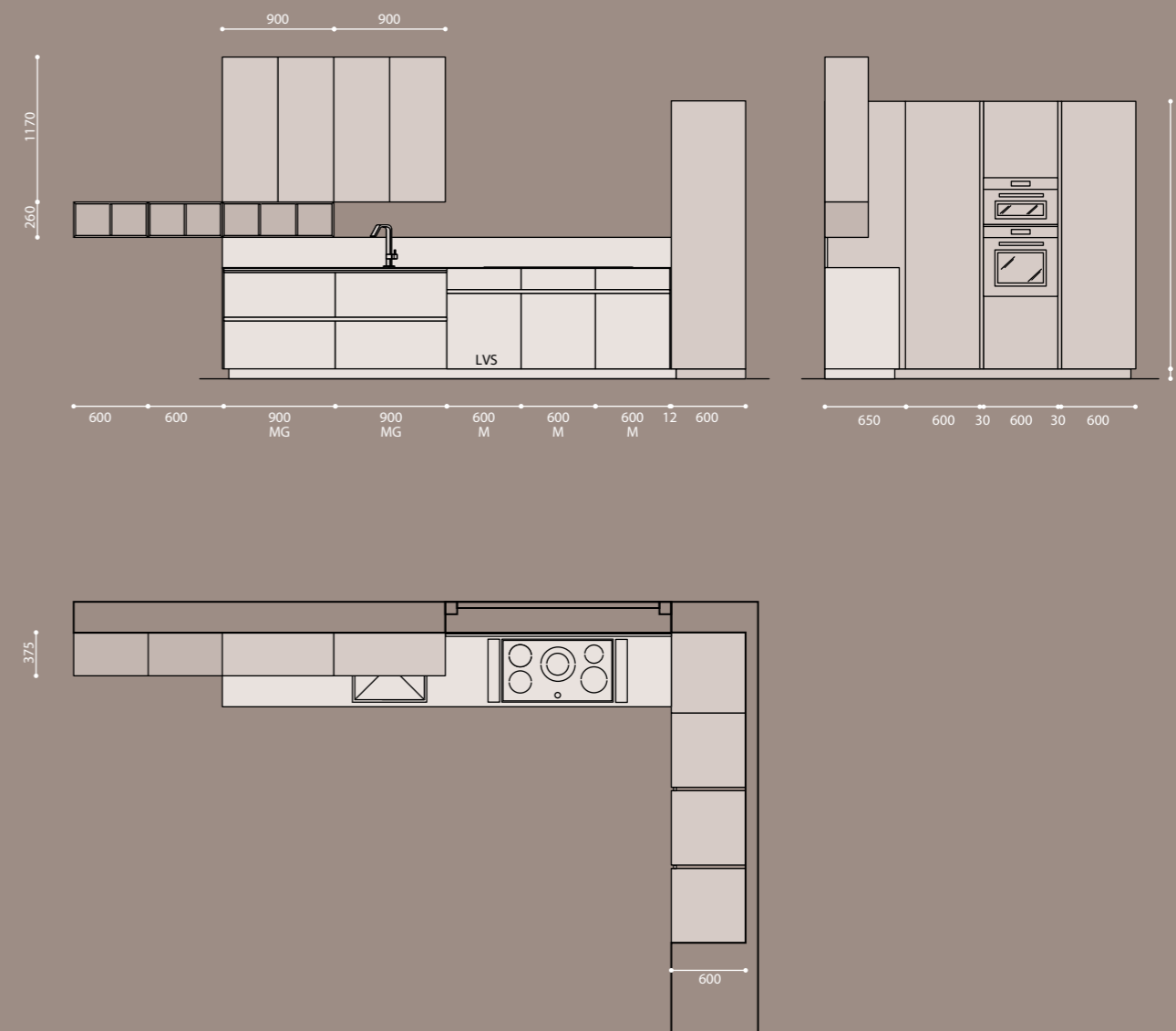

- 01. Elementi a giorno, laccato Bianco
- 02. Pensili, frontale fenix Grigio Bromo
- 03. Base M_onoliti gola, frontale fenix Grigio Efeso
- 04. Lavello in acciaio, Foster
- 05. Base M_onoliti, frontale fenix Grigio Efeso
- 06. Piano cottura ad induzione, Miele
- 07. Aspirazione, Bora
- 08. Piano di lavoro fenix Grigio Efeso
- 09. Forno e microonde, Miele
- 10. Colonne h 2160, frontale fenix Grigio Bromo

- 01. Open elements, Bianco lacquer
- 02. Wall units, fenix Grigio Bromo front
- 03. M_onoliti base unit with grip recess, fenix Grigio Efeso front
- 04. Steel sink, Foster
- 05. M_onoliti base unit, fenix Grigio Efeso front
- 06. Induction hob, Miele
- 07. Extraction, Bora
- 08. Fenix Grigio Efeso worktop
- 09. Oven and microwave, Miele
- 10. Tall units h 2160, fenix Grigio Bromo front

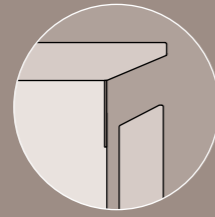
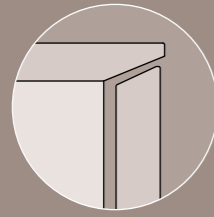

- laminato Malta Bianca
Malta Bianca laminate
- laminato Malta Canapa
Malta Canapa laminate

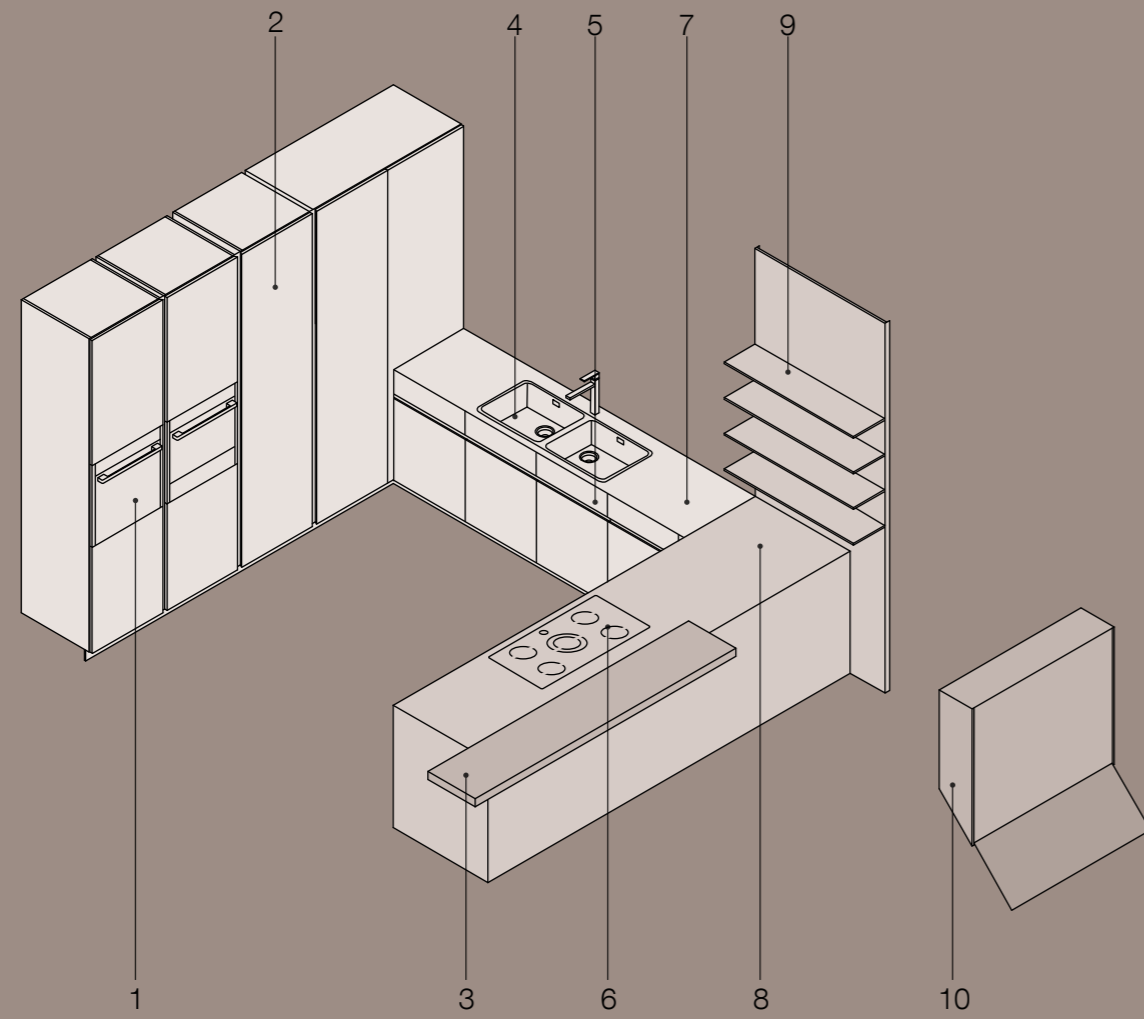

M_onoliti: M
M_onoliti gola: MG

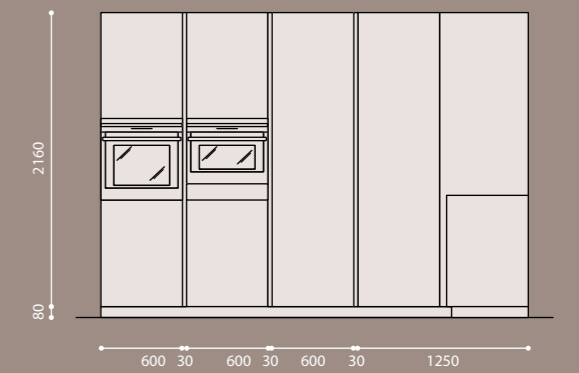
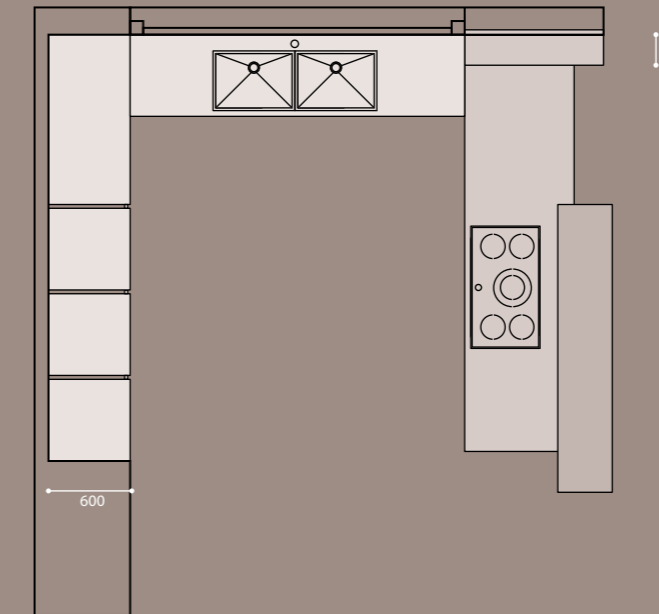
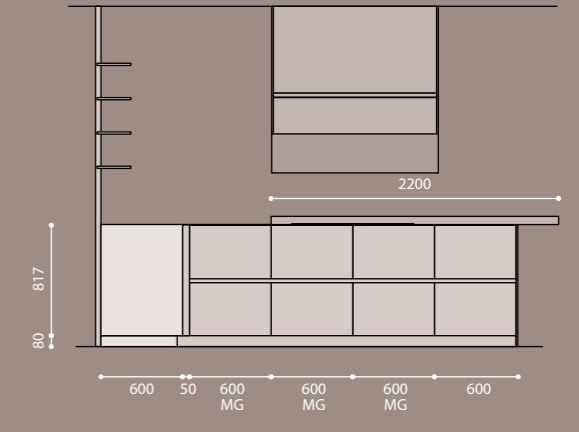
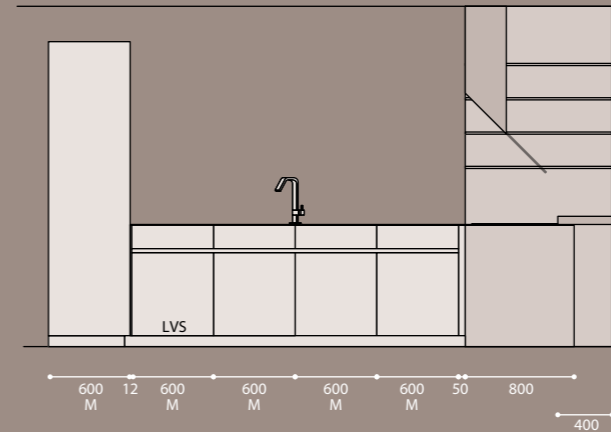

- 01. Forno e microonde, Neff
- 02. Colonne h 2160, frontale anta laminato Malta Bianca
- 03. Piano Snack Rovere Nodato Naturale
- 04. Lavello acciaio
- 05. Base M_onoliti, frontale laminato Malta Bianca
- 06. Piano cottura ad induzione, Neff

- 07. Piano di lavoro laminato Malta Bianca
- 08. Piano di lavoro laminato Malta Canapa
- 09. Boiserie, pannello e mensole, laminato Malta Canapa
- 10. Cappa isola Scirocco, Meson's

- 01. Oven and microwave, Neff
- 02. Tall units h 2160, Malta Bianca laminate door front
- 03. Breakfast bar in Natural Knotted Oak
- 04. Steel sink
- 05. M_onoliti base unit, Malta Bianca laminate front
- 06. Induction hob, Neff

- 07. Malta Bianca laminate worktop
- 08. Malta Canapa laminate worktop
- 09. Wall panelling, panel and shelves in Malta Canapa laminate
- 10. Scirocco hood for island unit, Meson's

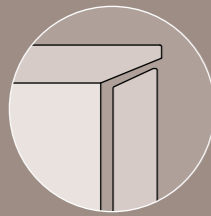

- materico Cemento
Cemento textured-melamine
- laminato Metallo Lamiera
Metallo Lamiera laminate

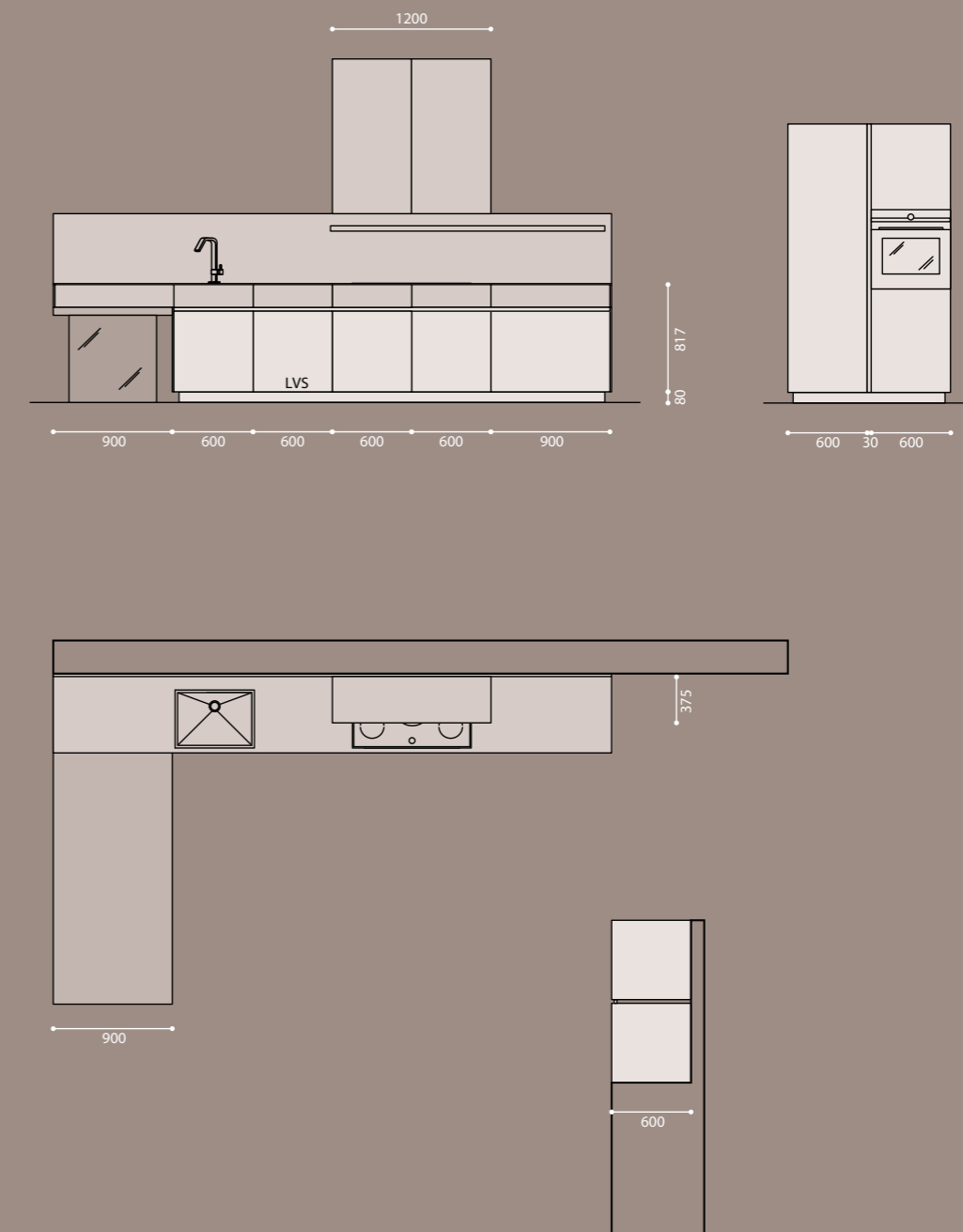
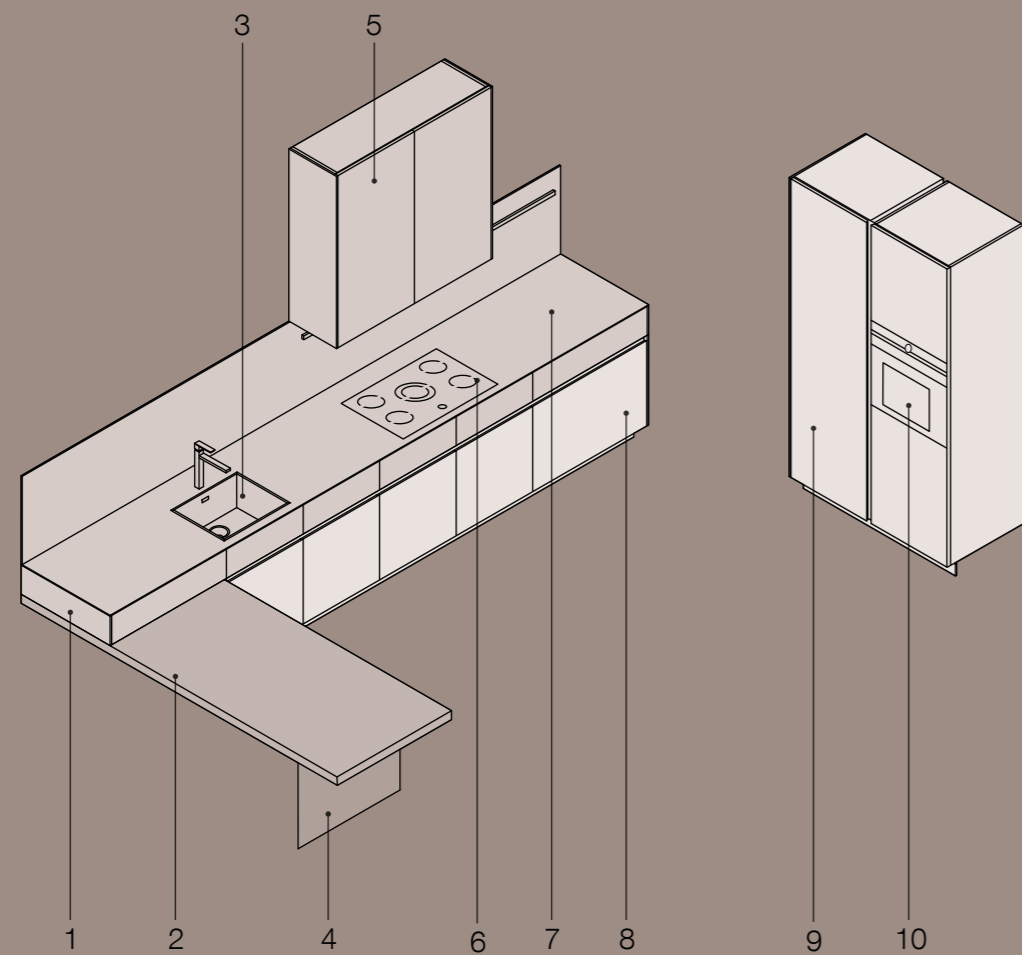

- 01. Cassetto, frontale laminato Metallo Lamiera
- 02. Penisola, Rovere Nodato Naturale
- 03. Lavello sottotop, Foster
- 04. Gambone in vetro
- 05. Pensili, frontale laminato Metallo Lamiera, cappa incassata

- 06. Piano cottura ad induzione, Siemens
- 07. Piano di lavoro laminato Metallo Lamiera
- 08. Basi M_onoliti, frontale cassetto laminato Metallo Lamiera, frontale anta materico Cemento
- 09. Colonne h 2030, frontale materico Cemento
- 10. Forno, Siemens

- 01. Drawer, Metallo Lamiera laminate front
- 02. Peninsular unit, Natural Knotted Oak
- 03. Undermounted sink, Foster
- 04. Glass Leg
- 05. Wall units, Metallo Lamiera laminate front, built-in hood

- 06. Induction hob, Siemens
- 07. Metallo Lamiera laminate worktop
- 08. M_onoliti base units, Metallo Lamiera laminate drawer front, Cemento textured-melamine door front
- 09. Tall units h 2030, Cemento textured-melamine front
- 10. Oven, Siemens

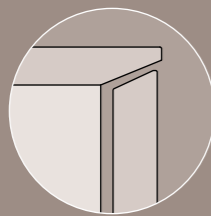

- materico seta Diamante
Seta Diamante textured-melamine
- laminato Pietra Calacatta
Pietra Calacatta laminate

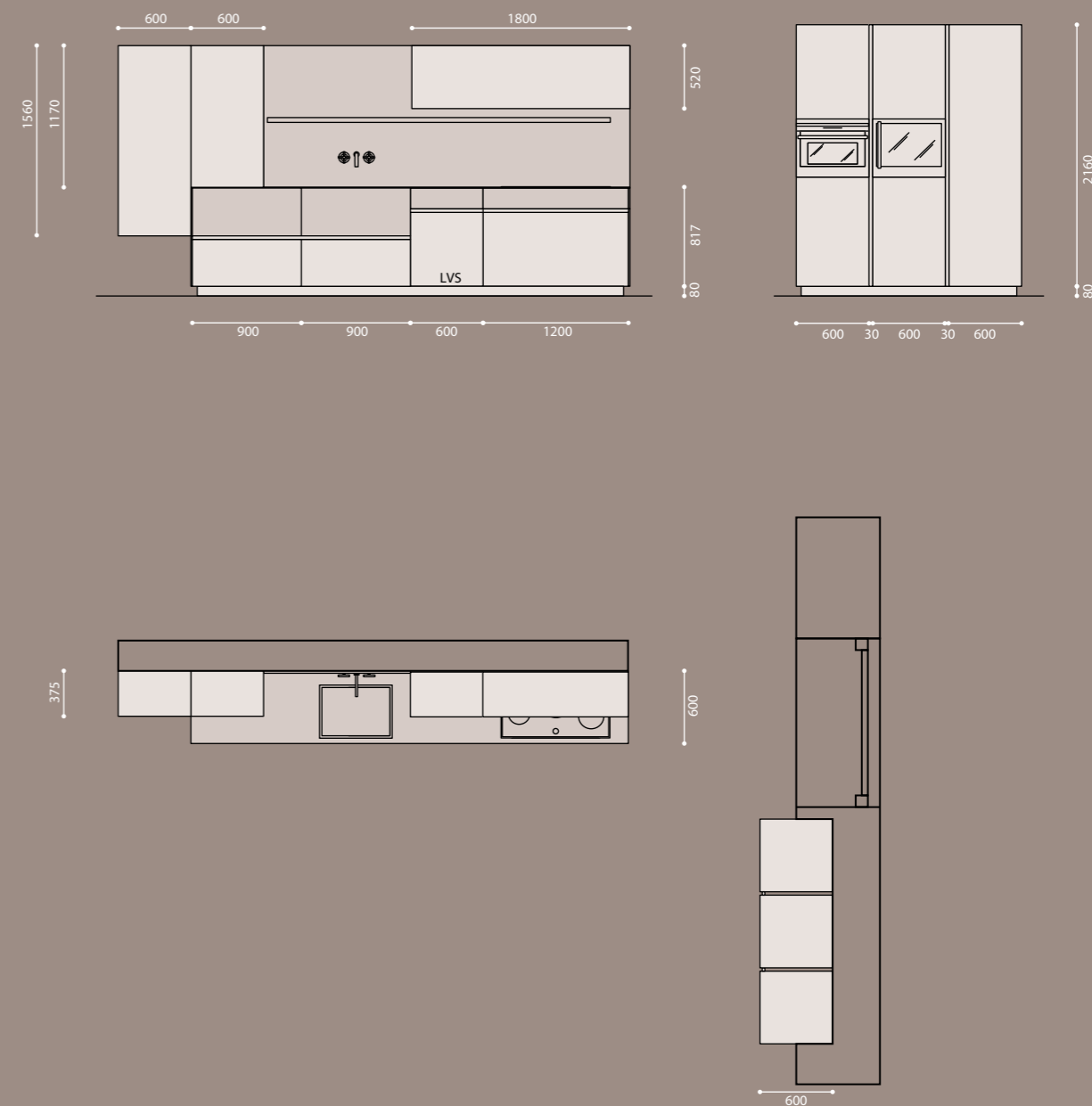
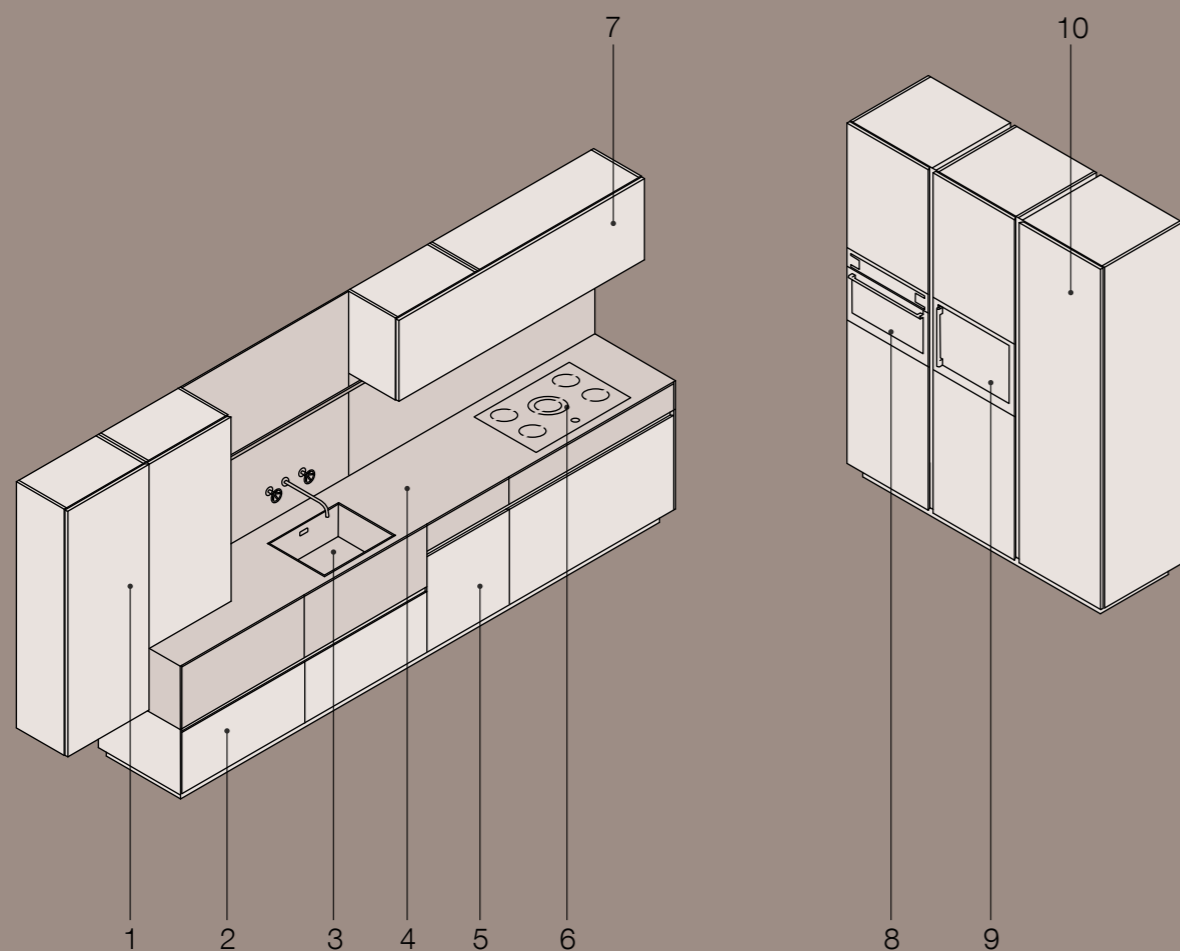

- | | |
|--|---|
| <p>01. Pensili, frontale materico seta Diamante</p> <p>02. Base M_onoliti, frontale primo cestone laminato Pietra Calacatta, secondo cestone materico seta Diamante</p> <p>03. Lavello integrato unicolor, 500 x 400</p> <p>04. Piano di lavoro unicolor Pietra Calacatta</p> <p>05. Base M_onoliti, frontale cassetto laminato Pietra Calacatta e frontale materico seta Diamante</p> | <p>06. Piano cottura ad induzione, AEG</p> <p>07. Pensile composto (600 + 1200), anta unica, frontale materico seta Diamante con apertura vasistas e cappa incassata</p> <p>08. Forno, AEG</p> <p>09. Cantinetta per vino, AEG</p> <p>10. Colonne h 2160, frontale materico seta Diamante</p> |
|--|---|

01. Wall units, Seta Diamante textured-melamine front
02. M_onoliti base unit, front of first deep drawer in Pietra Calacatta laminate, second deep drawer in Seta Diamante textured-melamine
03. Unicolor integrated sink, 500 x 400
04. Unicolor Pietra Calacatta worktop
05. M_onoliti base unit, Pietra Calacatta laminate drawer front and Seta Diamante textured-melamine front

06. Induction hob, AEG
07. Composed wall unit (600 + 1200), entire door, seta Diamante textured-melamine front with top-hung door and built-in hood
08. Oven, AEG
09. Wine cooler, AEG
10. Tall units h 2160, Seta Diamante textured-melamine front

CREDIT

CONCEPT MESON'S

FOTOREALISMO TALEADESIGN.IT

FOTOLITO LUCEGROUP.IT

GRAPHIC DESIGN TALEADESIGN.IT

PRINT GFP

SEPTEMBER 2016

Meson's si riserva la facoltà di apportare modifiche o migliorie in qualsiasi momento, anche senza preavviso. I campioni di colori e materiali hanno valore indicativo. Tutti i diritti sono riservati.

Meson's is entitled to make modifications and improvements at any time, even without notice. The colour and material samples have an indicative value. All rights are reserved.

MESON'S

Meson's Cucine srl

Via Gradisca, 1
33087 Pasiano di Pordenone
Pordenone Italy
T 0039 0434 614911
F 0039 0434 628042
www.mesons.it

Servizio Clienti

T 0039 0434 614900
F 0039 0434 628042
studiomesons@mesons.it

Servizio Utenti

T 0039 0434 614923
F 0039 0434 628042

International department

T 0039 0434 614972
F 0039 0434 628042
studiomesons@mesons.it

follow us on socials!



